

## 表面実装型水晶振動子 低抵抗型

## SMD CRYSTAL UNIT - LOW RESISTANCE TYPE

## TYPE: 49/U-SMD-L

**特徴**

低背型2.6mm max ~ 4.0mm max  
金属パッケージ抵抗溶接により高信頼性を確保  
低い等価直列抵抗

**Features**

Ultra low profile standard SMD type.  
(2.6 mm max ~ 4.0mm max height)  
Proven resistance weld metal package.  
Low motional resistance.

**一般仕様 / Standard Specifications**

## 1. 一般情報 / General Information

SUNLEAD Spec. : 49/U-SMD-L26 (L40)  
Holder Type : HC-49/U-S (Resistance Weld)

RoHS Compliant

## 2. 電気特性 / Electrical Specifications

Parameters	Specifications
Frequency Range	3.000 ~ 36.000MHZ
Mode of Vibration	AT-Fundamental
Load Capacitance	18pF
Drive Level	500 μW Max
Equivalent Series Resistance	<b>See Table</b>
Frequency Tolerance	± 50PPM
Frequency Stability Over Temperature	± 50PPM
Operating Temperature Range	-10 to +60 , -20to+70
Storage Temperature Range	-55 to +105
Aging at 25 1st. Year	± 5PPM

## 3. 外形寸法 / Demension

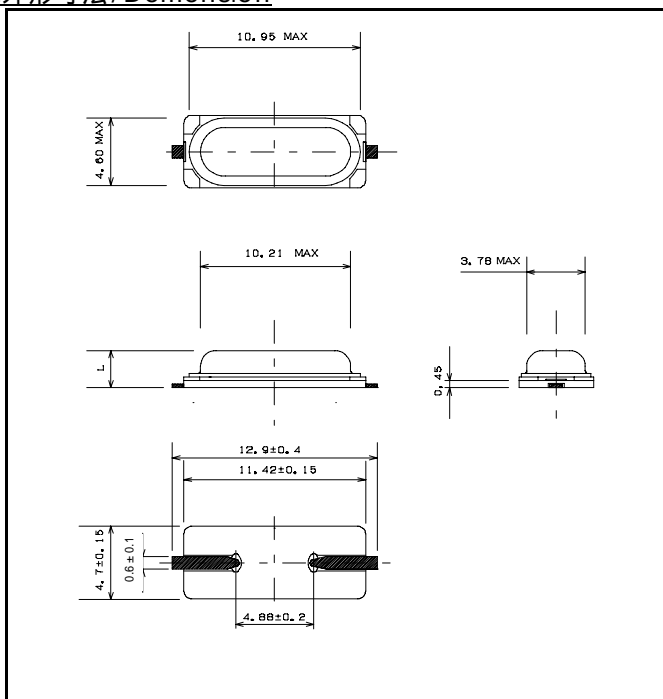

## 4. Table

Frequency Range (MHz)	Maximum ESR ( )	
	Rank A	Rank B
3.000000	100	200
3.072000	100	200
3.276800	75	150
3.500000 - <4.000000	50	100
4.000000 - <5.000000	40	80
5.000000 - <6.000000	30	60
6.000000 - <7.000000	30	60
7.000000 - <9.000000	20	40
9.000000 - <13.000000	15	30
13.000000 - <20.000000	10	20
20.000000 - 36.000000	10	20

Type	L (mm)
49U-SMD-L26	2.6 max.
49U-SMD-L30	3.0 max.
49U-SMD-L35	3.5 max.
49U-SMD-L40	4.0 max.